

The New Standard

The New Standard video wall series features a slim profile and a wide range of digital video input options (HDMI, DVI and DisplayPort). Like all GPO Display video walls, these displays are built for 24/7/365 operation. Optional Auto Condition Reporting (ACR) Lite provides basic real-time monitoring and diagnostics. Extreme Narrow Bezel video walls (1.7mm - 1.8mm combined bezel gap) and Ultra Narrow Bezel (3.5mm combined bezel gap) are available in 46", 49", and 55" screen sizes.

Features

Uniform Bezel

Extreme Narrow Bezel (ENB) displays feature a uniform bezel 0.9mm bezel on all sides for a tiled gap of 1.8mm. This makes for a cleaner, less-prominent bezel appearance when compared to other LCD video wall displays.

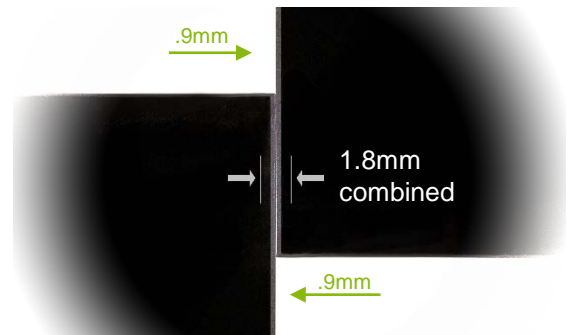

Auto-Aligning H- Mount

GPO Display's new & improved H-Mount video wall mounting system ensures quick, easy installation with virtually automatic alignment. The H-Mount frame matches the outline dimensions of the display, making for less measuring & re-measuring during the installation process. The unique channel system allows for access to individual displays without the dismounting of neighboring displays. H-Mounts even come with side covers/trim at no additional cost. Most importantly, H-Mounts prevent shifts in alignment over time- an issue commonly associated with front-accessible mounting solutions. For video wall arrays with three or fewer rows of displays, the H-Mount is the ideal solution.

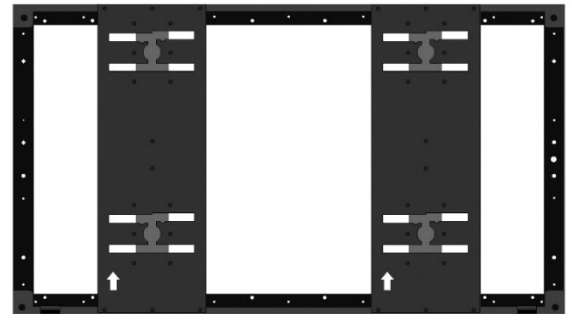

Optional Auto Condition Reporting (ACR) Lite System

ACR *Lite* is a basic version of our [Auto Condition Reporting](#) diagnostic/monitoring tool for video wall displays. Real-time status readouts for each display can be gathered on the ACR Hub (a device which sits in the RS-232 control path), on a PC running ACR software, or on an Android tablet or mobile device. From there, users can gather real-time information such as ACR network connectivity, internal display temperature, power state, and input activity. The ACR Android application also allows users to treat their phone as a remote controller, with power on/off, OSD menu access and other simple control functions.

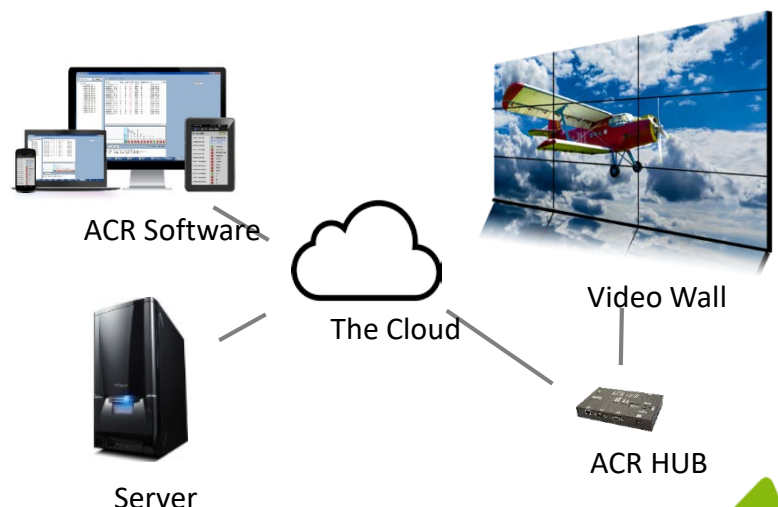

NSV49HLE

Panel Attributes

Screen Size (Diag.)	49"
Panel Technology	Commercial-grade IPS / Direct-LED backlight
Resolution	1920 x 1080
Pixel Pitch (mm)	0.55926 (H) x 0.55926 (V)
Surface Treatment	Hard coating (3H), Anti-glare treatment of front polarizer
Brightness (Typ.)	700nit
Contrast Ratio (Typ.)	1,300:1 / 500,000:1 (DCR)
Displayable Colors	10bit(D), 1.07 Billion colors
Viewing Angle	178° (min) / 178° (min)
Response Time (Typ. GTG)	12ms
Aspect Ratio	16:9
Tiled Bezel Width	1.8 mm (combined)
Refresh rate	60Hz

Dimensions, Power & Other

Dimension (W x H x D) / Weight (typ.)	Net	42.35" x 23.86" x 3.22", 51lbs
	Gross	46" x 29" x 8", 63lbs
VESA Pattern (mm)		600 X 400
Electrical Ratings		AC 100 - 240V (50/60Hz)
Power Consumption (Typ.)		150W / 1.8A
BTU rating (Typ.)		512
Mullion Compensation		SICP software or Remote control
Operating Temperature		32°F - 104°F
Operating Humidity Range		10~80%
Possible Display Type		Landscape and Portrait-Compatible
Industrial Reliability		60,000+ Hours
Warranty		Three Years (Limited Parts & Labor)

Connectivity

DisplayPort	1 x Input, (use DVI Output for daisy-chain)
HDMI	1 x Input, (use DVI Output for daisy-chain)
DVI	1 x Input, 1 x output
VGA	1 x Input, 1 x output
RS232	1 x Input, 1 x output
ACR Lite System	Optional
ACR Hub	Optional

Project-based Factory Color Calibration

All New Standard-series displays are assembled-to-order on a project basis. This allows for more accurate color calibration prior to shipment. By pre-calibrating and ensuring a match between displays associated with a single deployment, GPO Display reduces the need for post-installation calibration and adjustments.



Quick Preset Function

GPO Display can create "wild card" commands that allow users to get the most out of their video walls when a simple matrix switcher is in place. These "Quick Presets" allow you to recall a source layout with only a single command, reducing transition times between presets and minimizing programming of control systems.



(Optional) ACR HUB

The ACR Hub serves as both a central point for ACR Lite display monitoring as well as an IR extender for remote controllers. This allows users to address one or all sets in a video wall array via remote control.

- 24/7/365-Rated
- Built-in Video Wall Processor (up to 10x10 Natural Mode)
- Quick Preset Function
- Optional Auto Condition Reporting (ACR) Lite
- Includes [Video Wall Control Software](#)
- Includes necessary cables for daisy-chain of both control and video signals



Mechanical Drawing

Set Drawing

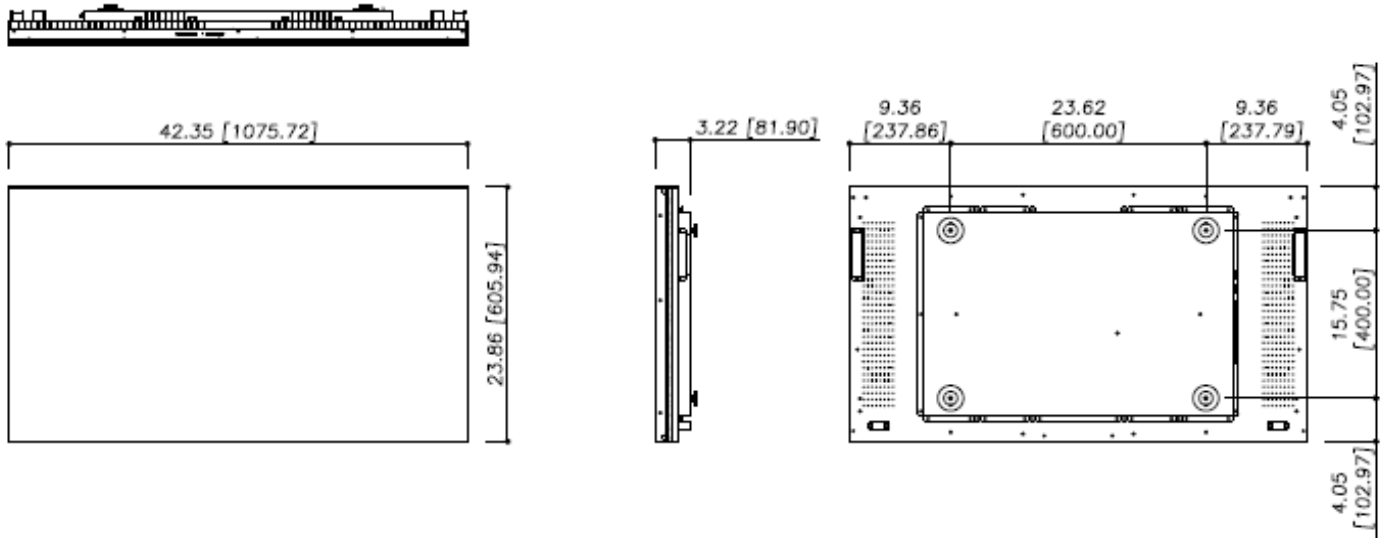

Set + H-Mount Drawing

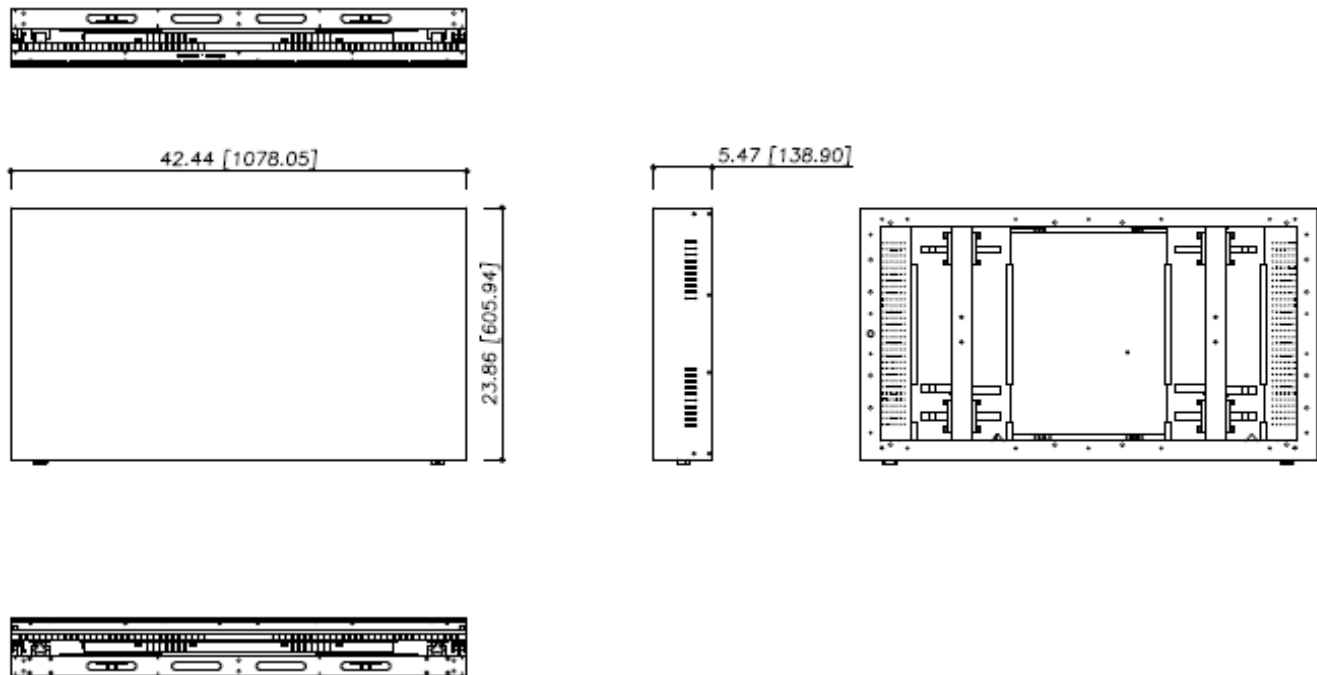

Note: GPO Display may change specifications and designs without notice

Accessories with product: RS-232 cable, DVI cable, VGA cable, AC Power Cord, Remote Control, Batteries for remote control, User manual & Software on USB Flash Drive



Mechanical Drawing

Set + Full Service Mount Drawing

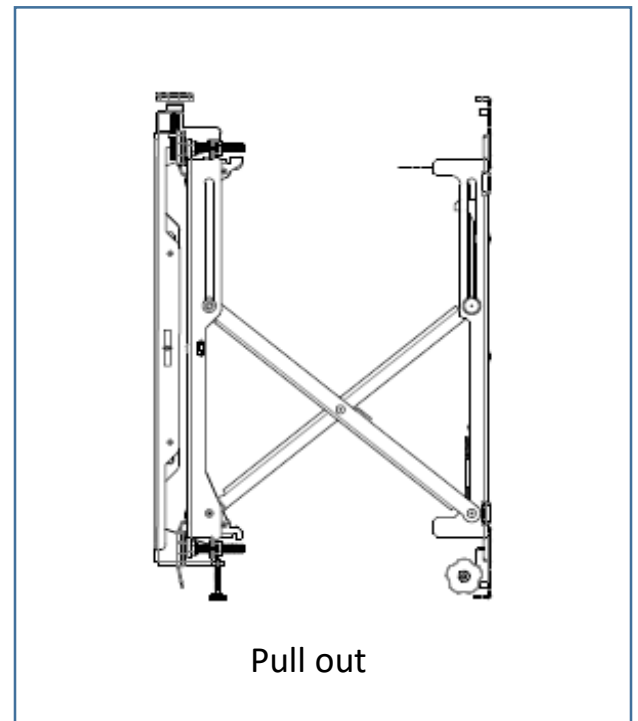
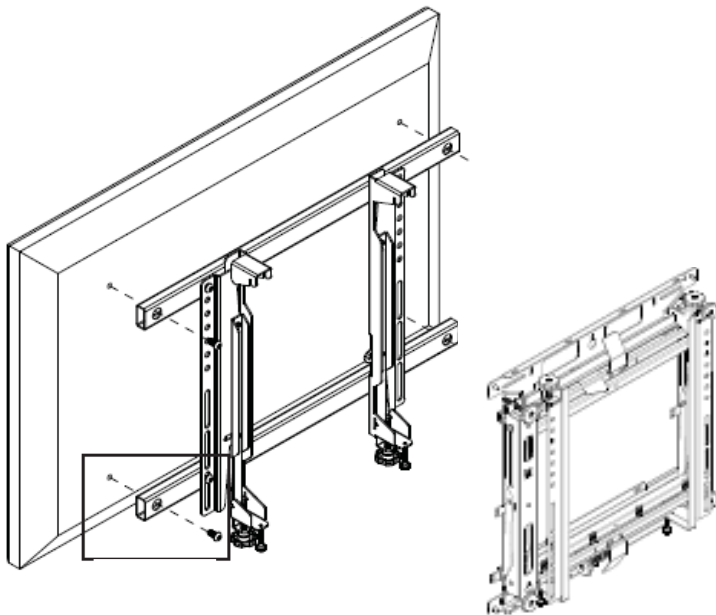
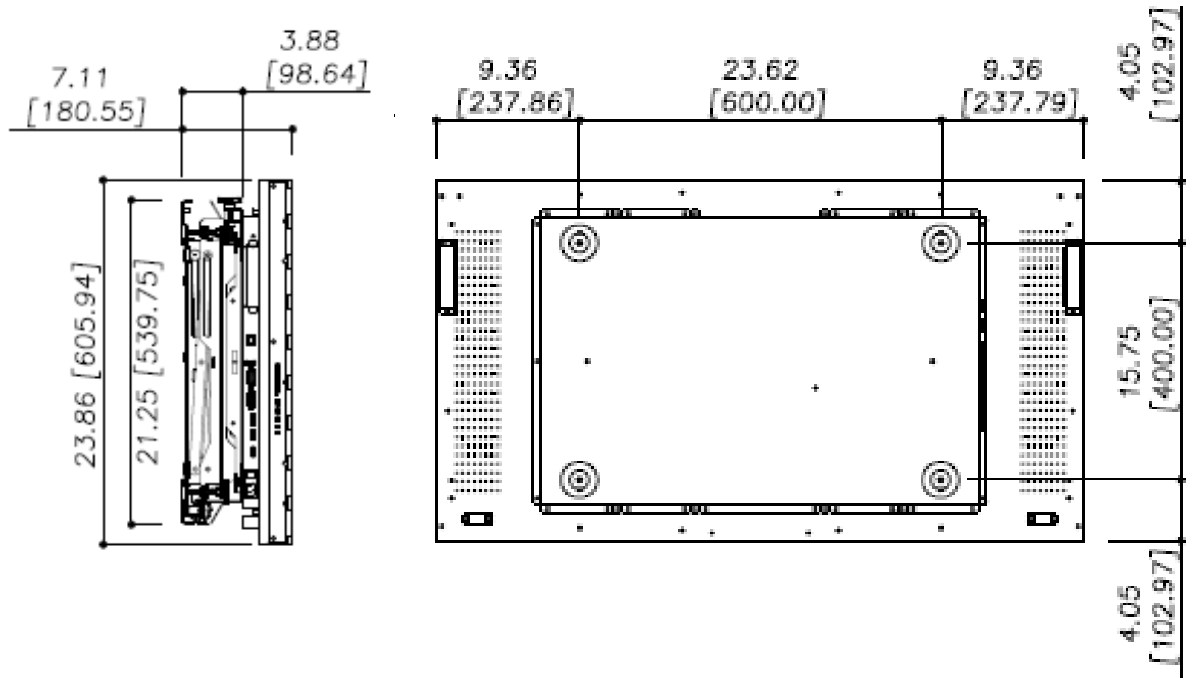

Note: GPO Display may change specifications and designs without notice

Accessories with product: RS-232 cable, DVI cable, VGA cable, AC Power Cord, Remote Control, Batteries for remote control, User manual & Software on USB Flash Drive