



STURDIGLASS - Videowall

The Sturdiglass option for Easy-4K video wall displays improves screen durability without compromising viewing experience. GPO Display uses the latest in optical bonding technology to affix high-grade, durable protective glass to the LCD surface. This ensures a strong, long-term bond that won't "bubble" or peel, even in the most demanding of applications.

Sturdiglass is ideal for displays placed in high-traffic, public settings where there is a high risk of impact. Touch video walls also benefit from Sturdiglass technology, with none of the internal reflection or parallax error that comes with installing separate pieces of protective glass in front of LCD panels. Optical bonding also prevents dust and moisture buildup associated with separate protective glass.

Features

Clarity Increase ↑

When separate protective glass is used, there is a small gap between the LCD panel and glass. This means that light bends when it passes through the air gap. This results in a loss in its intensity, affecting the screen's readability. Sturdiglass eliminates this issue entirely, providing unparalleled clarity.

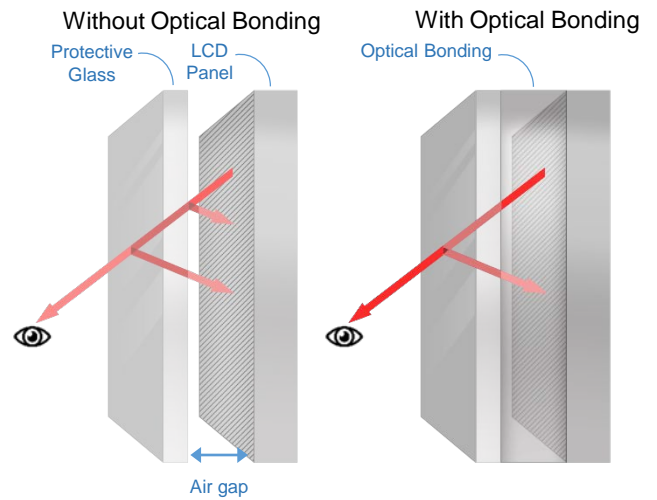

Glare Reduction ↓

Sturdiglass video walls feature Anti-Glare (AG) coating, allowing for their placement in a wider range of environments than other protective glass solutions. The elimination of the air gap between glass and LCD panel also means you will never have to contend with any *internal* reflection issues, either.

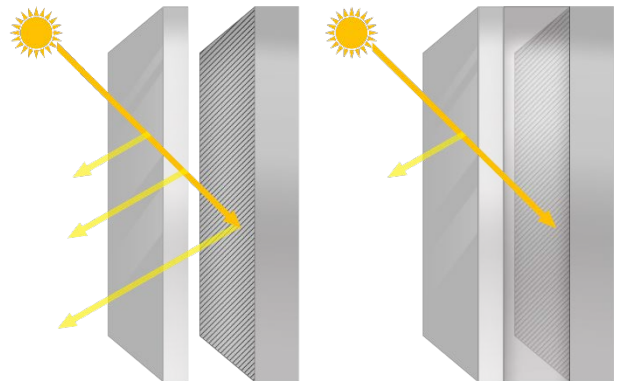

Durability Increase ↑

The additional resin layer in Sturdiglass' optical bonding provides increased physical durability to the LCD screen. Eliminating the gap between the LCD module and the panel increases the screen's resistance to scratches, dust, and fluids.

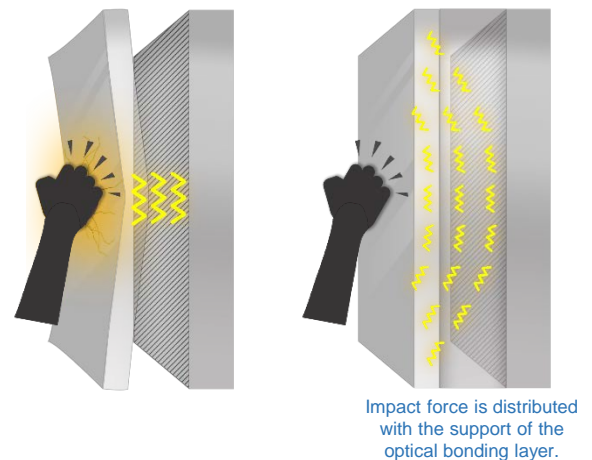

Features

Extreme Narrow Bezel

Extreme Narrow Bezel (ENB) displays feature a tiled gap of 1.7mm (1.15mm on top/left, 0.55mm on bottom/right). This is the slimmest possible bezel gap in this screen size on the market.

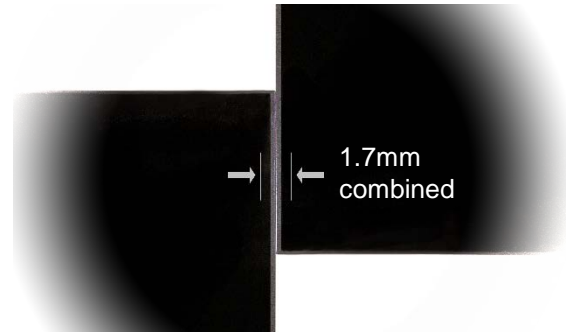

Easy-4k daisy-chaining

Expanding 4K/Ultra-HD content across large video wall arrays is made simple via support of HDMI 2.0 daisy-chaining. 4K content can be shown on video wall arrays of up to ten displays using a single HDMI cable without signal amplification, making stunning 4K video walls possible without the added cost of video wall processors or multi-output computers. Full-HD (1920x1080) content can be carried through up to 25 displays without signal amplification. With distribution amplifiers in place, arrays of up to 256 displays are possible.



Optically-bonded “Sturdiglass” protective glass

Our “Sturdiglass” video walls feature an anti-glare, anti-streak, and fingerprint-resistant protective glass. Each piece of glass is bonded to the LCD panel surface for safe use in virtually any indoor environment. This durable, optically-bonded glass eliminates parallax issues and faint reflections between the glass and panel surface. This durable glass also features anti-glare and smudge-resistant coating



Options

CALKIT-EK color calibration kit

Are you looking for the highest level of color uniformity for your videowall? Then CALKIT-EK is the solution for you. CALKIT-EK is an automatic color calibration kit specifically designed for our Easy-4K (EK) series displays. CALKIT-EK provides serious color perfectionists with the perfect combination of color precision, speed, and controls to fit any configuration of videowall. You'll no longer risk spending hours or even days calibrating to achieve perfect color balance.

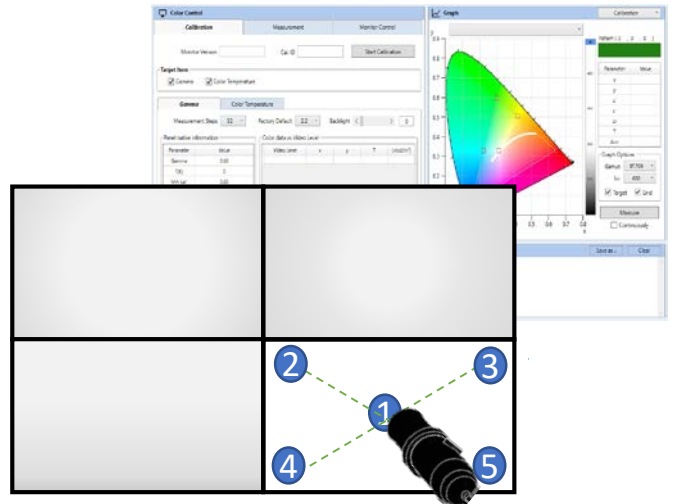

HD-SDI In/Out

Easy-4K displays bring users expanded connectivity in the form of a daisy-chainable HD-SDI input. Broadcast engineers have long known the benefits of HD-SDI over HDMI, such as significantly longer run distance (~300m), instantaneous switching, locking connectors, and signal reliability. These displays' HD-SDI daisy-chain capability also eliminates the need for conversion, which can increase cost and serve as an additional point of failure.

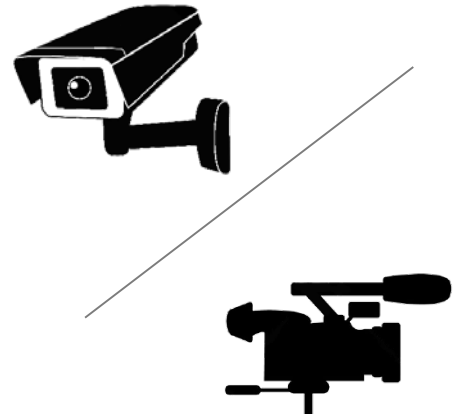

Auto-Aligning Mounts

New [Z-Shift Video Wall Mounts](#) allow for a quick, safe installation and easy alignment, which is especially important with Extreme Narrow Bezel displays. Z-Shift mounts prevent alignment "drift" during installation or service, ensuring that displays remain in perfect alignment throughout the course of the video wall's lifetime. Side covers/trim are included for a clean, finished appearance from almost any angle.

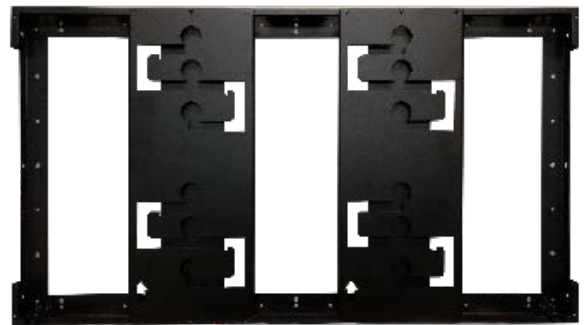

EK49HLU-SG

Panel Attributes

Screen Size (Diag.)	49"
Panel Technology	Commercial-grade IPS / Direct-LED backlight
Resolution	1920 x 1080
Pixel Pitch (mm)	0.55926 (H) x 0.55926 (V)
Surface Treatment	Hard Coating (3H), Anti-glare treatment of front polarizer
Brightness (Typ.)	700nit
Contrast Ratio (Typ.)	1,300:1 / 500,000:1 (DCR)
Displayable Colors	10bit(D), 1.07 Billion colors
Viewing Angle	178° (min) / 178° (min)
Response Time (Typ. GTG)	12ms
Aspect Ratio	16:9
Tiled Bezel Width	3.5 mm (combined)
Refresh rate	60Hz

Dimensions, Power & Other

Dimension (W x H x D), Weight	42.43" x 23.93" x 4.09" / 53lbs
VESA Pattern (mm)	400 x 300
Electrical Ratings	AC 100 - 240V (50/60Hz)
Power Consumption (Typ.)	150W / 1.8A
BTU rating (Typ.)	512
Sturdiglass	2mm Optically-bonded protective glass
Operating Temperature	32°F - 104°F
Operating Humidity Range	10~80%
Possible Display Type	Landscape and Portrait-Compatible
Industrial Reliability	60,000+ Hours
Warranty	Two Years (parts & labor)

Connectivity

DisplayPort	1 x Input
HDMI (up to 3840 x 2160)	1 x Input, 1 x output
HD-SDI (optional)	1 x Input, 1 x output
RS-232	1 x Input, 1 x output
Ethernet (RJ45 for control & monitoring)	1 x Input
USB (for service only)	1 x Input

Project-based Factory Color Calibration

All Easy-4K displays are assembled-to-order on a project basis. This allows for more accurate color calibration prior to shipment.



By pre-calibrating and ensuring a match between displays associated with a single deployment, GPO Display reduces the need for post-installation calibration and adjustments.

Optically-bonded "Sturdiglass" protective glass

"Sturdiglass" video walls feature an anti-glare, anti-streak, and fingerprint-resistant protective glass. Each piece of glass is bonded to the LCD panel surface for safe use in virtually any indoor environment.



Easy-4K daisy-chaining

4K content can be shown on video wall arrays of up to ten displays using a single HDMI cable without signal amplification, making stunning 4K video walls possible without the added cost of video wall processors or multi-output computers.



- 24/7/365-Rated
- Built-in Video Wall Processor (up to 11x11 Natural Mode)
- Color temperature preset (3200k/5600k/6500k/7800k/9300k)
- Includes [Video Wall Control Software](#)
- Includes necessary cables for daisy-chain of both control and video signals

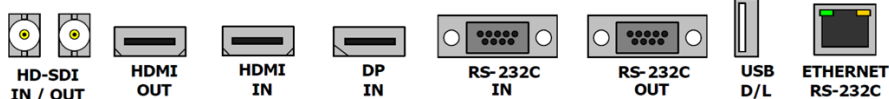

Mechanical Drawing

Set Drawing

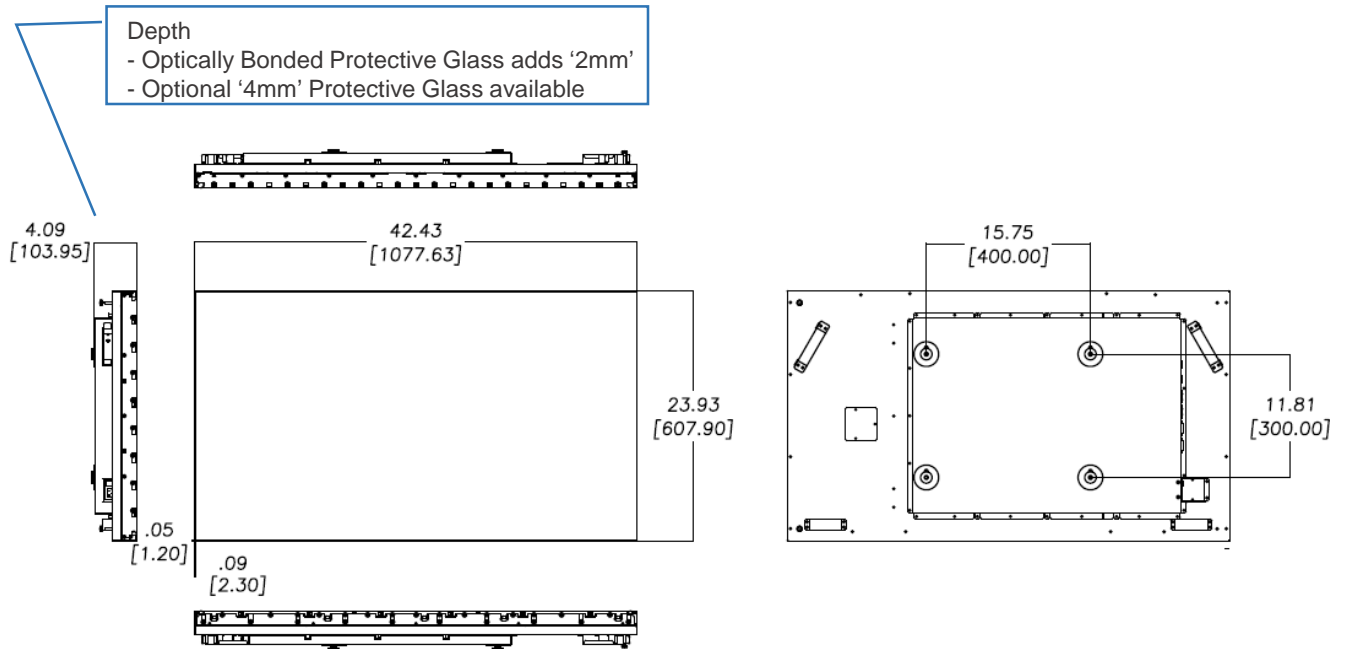

Set + ZLM Mount Drawing

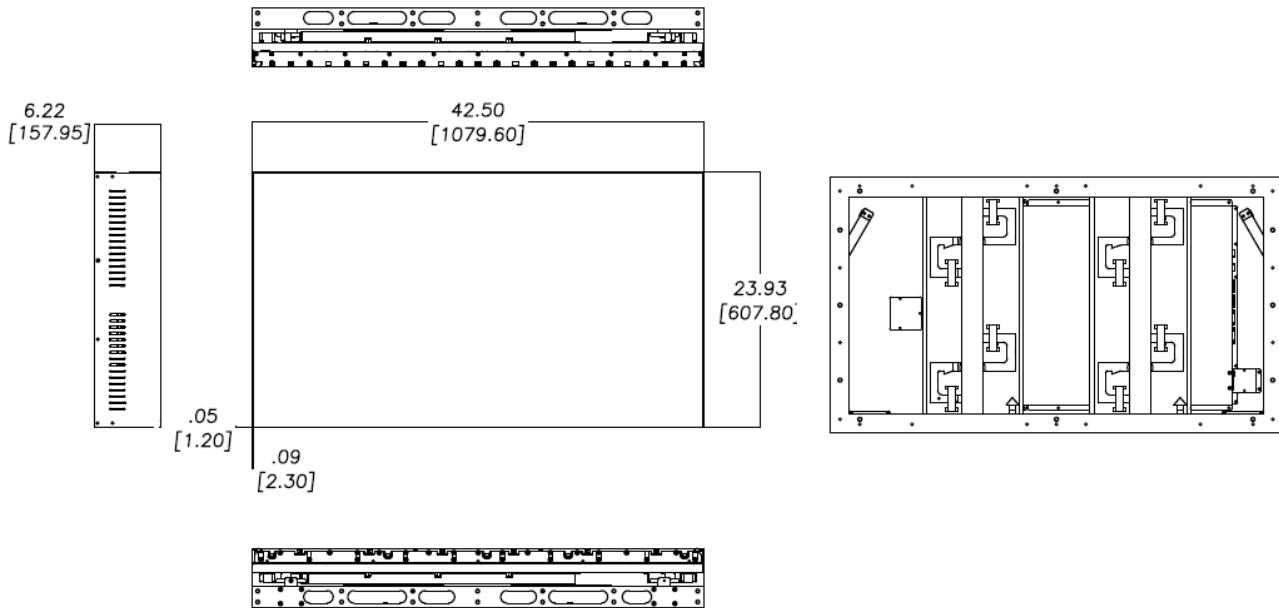

Note: GPO Display may change specifications and designs without notice

Accessories with product: RS-232 cable, HDMI cable, AC Power Cord, Remote Control, Batteries for remote control, User manual & Software on USB Flash Drive



Mechanical Drawing

Set + Full Service Mount Drawing

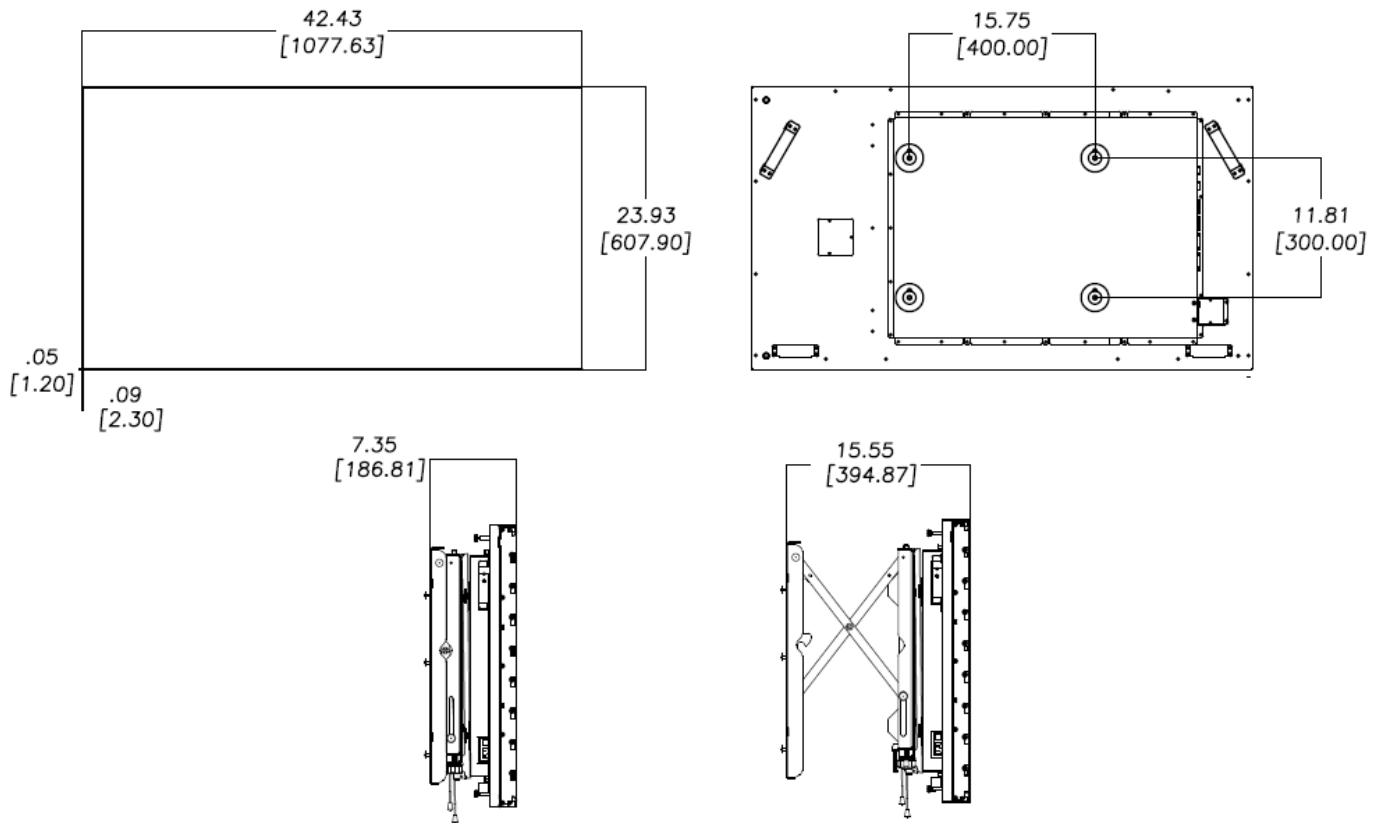

Note: GPO Display may change specifications and designs without notice

Accessories with product: RS-232 cable, HDMI cable, AC Power Cord, Remote Control, Batteries for remote control, User manual & Software on USB Flash Drive

